



Antitheft Alarm System for Electric Motor Pumps

Pradnya Thorat¹, Ravindra N. Rathod²

Undergraduate Student, Government College of Engineering Karad, Satara, India¹

Assistant Professor, Government College of Engineering Karad, , Satara, India²

Abstract: An anti -theft system for electric motor includes controller, feedback circuit and alarm circuit. The feedback circuit continuously monitor the electric motor load, if the motor load is disconnected controller gives alarm with the help of buzzer This paper reports the design and development of an innovative anti –theft alarm system for electric motor pumps. The pumps are frequently stolen which as serious impact on agricultural production in accordance with the advantage of current transformer, MAX 485 Low power slew rate limited transceiver. The system consists of three main parts a PIC microcontroller, Current transformer and signal driver and feedback circuit. The Electric Motor costs are very high, when motors are on,it's very simple to detect the stealing of cables and motors when motors are off,it's very difficult to detect the stealing of the motors. The unit is part of motor driving circuit, cannot be identified easily as an anti-theft electric motor by the burglar

Keywords: Agriculture, alarm system, current transformer, PIC microcontroller, relay, pond, canal, electric water pump, nursery, intruder, yacht etc.

I. INTRODUCTION

Previously anti-theft devices are made to prevent theft of motor vehicle, boat and yacht, car, and truck etc. Similarly, anti-theft systems are develop to prevent theft in retail show room, library. An anti-theft device for electric water pump motor includes current transformer which is widely used for metering and protecting relays. The Electric water pump motors are installed for away on water well , water resources like rivers , canals , ponds – standing water etc. , and it is very difficult to monitor the electric water motor as they are installed at far away distance , their monitoring is difficult as motors are in off conditions , the thieves have good changes to steal these electric water pumps as they are in off conditions , and in remote areas , which cost very high , these electric water pumps are chosen according to the need of water from 0.5 hp to 10 hp which costs near about seven thousand rupees to several thousand rupees , which will be great loss for the small scale farmers in terms of money as well as agricultural production loss. The anti-alarm system proposed in view of application in nursery, low cost green houses for vegetables production, Agro-tourism.

A. Selecting an anti-theft alarm system for electric water pump

There are several cases found for stealing of electric water pumps in rural India, where people are complaining about stealing of electric water pumps, and there is no remedy for this problem and hence there is demand from the farmers, When the electric water pumps are on,it's very simple to detect the stealing of cables and motors but it is very difficult to detect the stealing, when the electric pump are in off condition

B. Objective and Scope of the system

The objectives of this system are

1. To design and develop the system which detect the stealing of the electric water pump motor
2. To give the alarm when stealing of electric water pump motor has been detected
3. To make a product design, which looks like an internal part or driving part of the electric water pump which is not easily identified by the intruder.

The scope of the system

The anti – theft alarm can be implemented where the agricultural field, nursery for plant development, green houses for vegetable production, water pumping stations and agro – tourism,irrigation, fish-pond operation, livestock watering, building and houses with sufficient water supply etc.

II. SYSTEM ARCHITECTURE

Today theft of motor is great concern because of its high cost and reliability of farming on motor; it is also not affordable for farmers to buy new motors,this is the system which provides security and indication for the electric water pumps at a very low cost compared to the cost of electric motor being stolen the anti- theft alarm system cost nearly 5 % of electric motor. This is system is suitable for detecting theft of electric water pump motor which are installed at remote location. There are so many applications where remote pumping is done with the help high cost electric motors such as irrigation, fish pond aeration, livestock watering, building and houses. This system has typical rural and remote application



This anti-theft alarm system consists of these parts, A PIC Controller, current transformer, motor on/off detection and Alarm system

The system architecture of anti-alarm system as shown in fig 1.

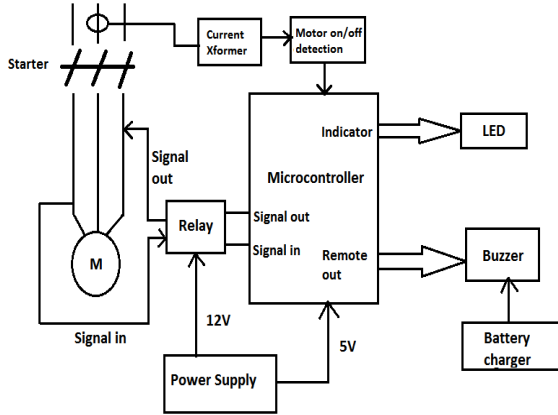

Fig 1: Architecture of anti -alarm System

A. PIC16F1503 Microcontroller

This is low cost and easily available microcontroller which has 14pins, we do not need to connect multiple outputs and inputs, this has sufficient pins to connect input and output. it has 3.5kb linear program memory and 128 bytes of linear data memory in this microcontroller PORT A will be configured as input port and PORT C will be configured as output port, signal in from the current transformer is connected to the one of the pin of port A, and the alarm circuit is connected to the port C of PIC16F1502 Microcontroller

B. Current Transformer

Current transformer is used in electronic equipment's and widely used for metering and protecting relays in the electrical power industry. The current transformer which have turns ratio 1000:1, it means the current on primary side is 30A and that on the secondary side is 30mA.

C. Motor on/off Detection

The motor on/off detection circuit as shown in fig. 2. which consists of current transformer with turns ratio 1000:1 transforms 30A current into 30mA current, which continuously sense electric water pump is in the circuit or not gives input signal to microcontroller in the form of the voltage provided by divider network as shown in the circuit.

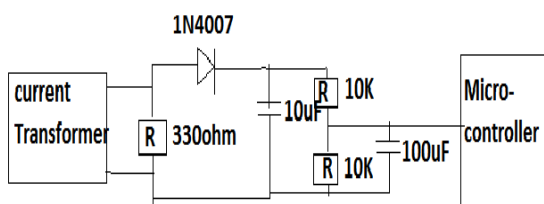

Fig .2 Motor on/off detection circuit

D. Signal driver and feedback circuit

The signal driver circuit consists of Two 12 V Relays in two PC817 opto coupler which isolates 12V power from 5V power supply the signal in and signal out signals are decided by PIC 16F1503 Microcontroller. The signal driver and feedback circuit is as shown in figure 3.

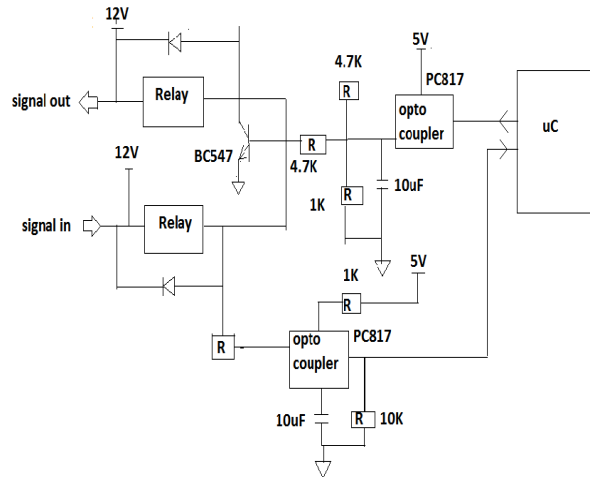

Fig.3. signal driver and feedback circuit

E. Alarm circuit

The alarm circuit consists of Two Max 485 which acts as transmitter and receiver, to the receiver side 12 V buzzer is connected, which will be continuously on when the Electric water pump will not in the circuit. To one of the Max485 Microcontroller output pin is connected, which gives you the signal when the electric water pump not in the circuit as shown in fig .5. To the 12 V buzzer a 12 V dc adaptor is connected,even though intruder cuts the power supply the external adaptor supplies the power to the buzzer.

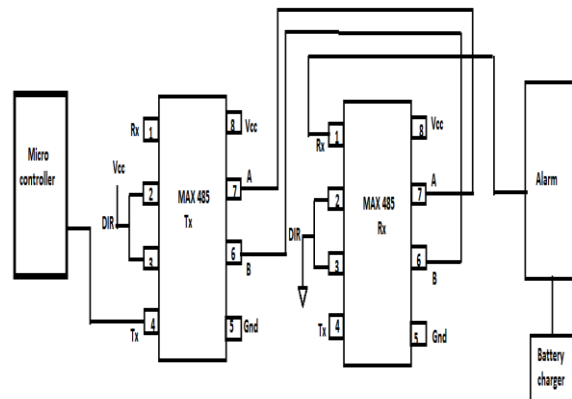

Fig 4. Alarm circuit

III.RESULTS

The system will automatically detect if motor is disconnected from the circuit and gives alarm.

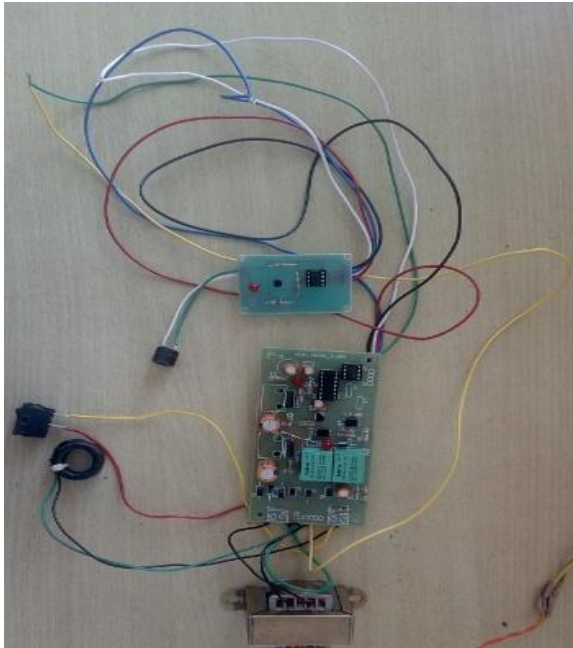

Fig. 5. Proposed anti-theft alarm system for electric - water pump

- [7] Johanne Bacusmo ,” Solar water pumping system”,
www.groundwaterinternational.com oct 2013
- [8] U.S. Patent “Anti -theft device for motor vehicles”, Patent number
5085061 date feb4,1992.

BIOGRAPHY



Ravindra N. Rathod was born in 14/06/1982 , he received is M. Tech degree from NIELIT, Aurangbad ,India in the field of Electronics Design and Technology , Currently he is working as an assistant professor in GCE , Karad .His research fields include electronic system design , control system and optimization , micro strip antennas

IV. CONCLUSION AND FUTURE SCOPE

The system is low cost, efficient, low power consumption easy to use to protect the electric water pumps which are installed at remote location from theft. it also detects the functionality of the motor. The future scope of the system is including GPS system which will monitor the location of the motor, where two or more than two electric water pumps motors are used. The system can be developed to prevent dry run of the motor. The system can be controlled with the help of android application program.

ACKNOWLEDGMENT

We would like to express our gratitude towards Meghdoot Agro Industrial equipment, Sangli for their kind cooperation and encouragement which helped us in completion of this system

REFERENCES

- [1] <http://meghdootagro.com/>.
- [2] Somboom phongphu and Panya Srichandr, Development of motor cycle Anti-theft alarm Singapore IPCSIT, 2011, vol. 7.
- [3] Arthur D. Little, “A Vehicle Anti -theft security system design,” Technical Report, U.S. Department of commerce vol. 2, PB-296 809
- [4] Sagar Khole , Tushar Kolape , Mrs .A.P. More , “Automated Drinking water supply system and theft identification using Embedded Technology,” in IJIRCCE , Vol 3, Issue 3, March 2015
- [5] Juan Huan , Xingqiao Liu “A Burglar Alarm System Based in ZigBee and GSM for Aquaculture,” Sensor and Transducers, Vol .175 , Issue 7, July 2014 ,pp.273-278
- [6] M.V.N.R. Pavan Kumar “Water Anti-theft and Quality Monitoring System by using AVR and SCADA”, IJRAT, vol.2, No.04, April 2014 E-ISSN:2321-9637